

REALTECH SUPER HIGH STRENGTH CERAMIC PIPE - BEND

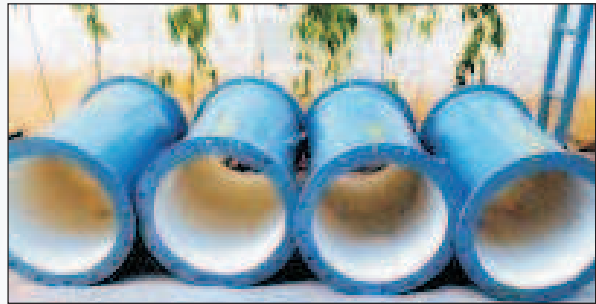

A company deal with saving concept

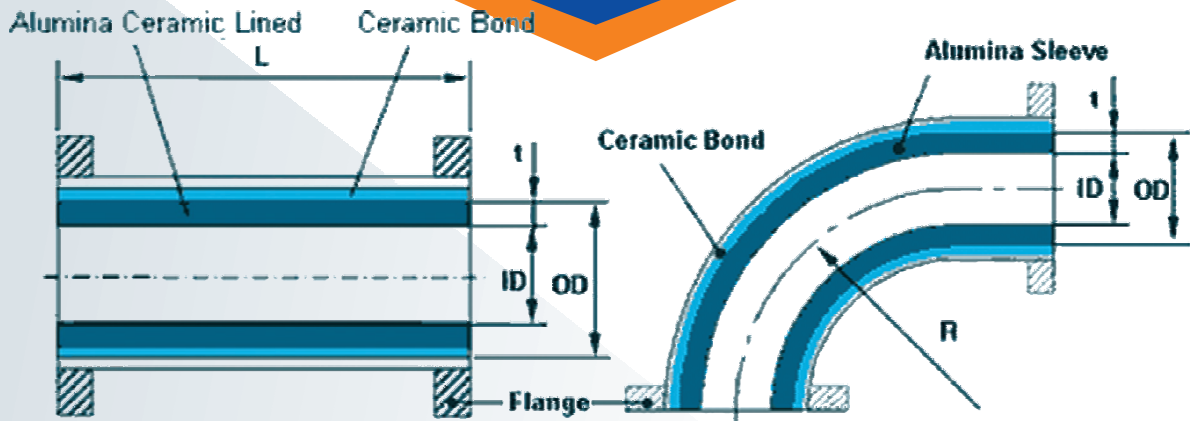

REALTECH CERAMIC PIPE - BEND

HI-TECH now offers REALTECH High Alumina Ceramic Lined Pipe and Bend for highly wear prone application such as Coal Fired Power Generation, Mining, Cement, Steel, Mineral Processing Industries.

REALTECH offers product designed to meet exacting requirement in cost effective manner. The choice of High Alumina Pipe and Bend ensures excellent wear and corrosion resistant properties. Our engineers are available for customer services for application development including Material Selection, Lining design, Fabrication and Installation. Alumina shape, size shall be designed to suit the final application of the Pipe and Bend.

The Hardness of REALTECH Ceramic Lined Pipe and Bend is next to Diamond which ensures extremely hard and wear resistant material. It can last longer than any other conventional material to take abuse of bulk material handling. In addition it retain its highly wear resistant properties at high temperature. REALTECH is also inert to all most all chemicals and thus providing excellent corrosion resistant properties against chemicals.

Typical Application :

coal pipe and bend / fly ash pipe and bend / lime stone pipe and bend / cock Pipe and Bend.

Properties :	REALTECH 90
Alumina content	90%
Colour	Black
Density gm/cc	3.60
Hardness MPH	9
Water Absorption	Nil
Max. Temp.	1500 C

Available Size :

Starts from 80 NB to 300 NB with any Degree and Radius.

Available with loose Flange / Matching Flange or as per Drawing.



Office : H-610, Titanium City Centre,
B/s. IOC Petrol Pump, 100 Feet Road,
Sachin Tower, Satellite, Ahmedabad-380 015.

Regd. Off. :A/74, Ekta Tower,
Vasna Barage Road,
Vasna, Ahmedabad-380 007.

Ph.: (O) 08866499777 M.: 9426075044, 9426511321.

E-mail: info@hitechcorporation.com Web.: www.hitechcorporation.com