



Automatic Draining of Condensate in Air Compressor and Air Drying Applications

Bulletin
210,262 Series

Timer Drain Valves

General Description

The Asco Timer Drain Valves are designed for automatic draining of condensate created in Air Compressor and Air Drying applications. This eliminates the need for manual draining and protects systems from flooding. Some locations where this product can be installed are compressor discharge lines, separators, receiver tanks, filters, drip legs, dryers and other compressed air equipment.

This product line combines a solid state electronic timer together with a proven reliable **ASCO Spade Connection** solenoid valve. By choosing from a large variety of valve sizes and adjusting the on-off ranges on the timer, the user is able to customise for their exact drainage requirements.

Features - Electronic Timer

- Selectable timing ranges (2-40 seconds "on", 30 seconds - 45 minutes "off")
- Input voltage 24 - 240 V AC/ DC.
- Manual override for test/ reset
- LED lights to indicate timing phase
- Spade Connection Coil with Gasket (IP 65)

Features - Solenoid Valves

- Epoxy moulded Spade Connection Solenoid Enclosure
- Heavy duty Class F (Class H - optional)
- Rugged brass bodies (Stainless steel body - optional)
- Resilient seating for leak tight shutoff
- Easily maintained with replacement parts available Worldwide
- Large selection for customisation to specific applications



Technical Specifications - Solenoid Valves

Pipe Size (In.)	Orifice Size (mm)	Kv Flow Factor	Operating Pressure Differential (Bar)							Maximum Fluid Temperature (C)		Spade Connection Coil Solenoid Enclosures (WPSC) IP65, Brass Body	Watt Rating/ Class of Coil Insulation	
			Min	Maximum AC			Maximum DC						AC	DC
				Air-Inert Gas	Water	Lt. Oil@ 300 SSU	Air-Inert Gas	Water	Lt. Oil@ 300 SSU					
1/4	3.2	0.35	0	20	20	14	5	4	4	80	65	WPSCB262D232	10.5/ F	11.2/ F
1/4	4	0.5	0	12	13	10	2.5	2.5	3	80	65	WPSCB262C202	10.5/ F	11.2/ F
3/8	16	3	0	10	10	7	3	3	3	85	65	WPSCB210C93	10.5/ F	11.2/ F
3/8	16	3	0.35	20	20	20	-	-	-	80	-	WPSCB210C6	16.7/ F	-
1/2	16	4	0.35	14	10	10	9	7	7	85	65	WPSCB210D2	6.0/ F	11.2/ F
1/2	16	4	0.35	20	20	20	-	-	-	80	-	WPSCB210C7	16.7/ F	-
3/4	19	5	0	9	9	7	3	3	3	85	65	WPSCB210D95	10.5/ F	11.2/ F
3/4	19	6	0	24	20	14	-	-	-	95	-	WPSCB210B26	15.4/ F	-
1	25	13	0.35	9	9	9	9	9	9	85	65	WPSCB210D4	6.0/ F	11.2/ F
1	25	13.5	0	20	15	8	-	-	-	90	-	WPSCB210B27	20/ F	-

Refer to ASCO catalogue with respect to the bulletin numbers for further specifications of solenoid valves.

Technical Specifications - Electronic Timer

Supply Voltage	: 24 - 240V AC/ DC
Current Consumption (Timer)	: 4 mA max
Operating Temperature	: -10° C to 50° C
Environmental Protection	: Weatherproof IP65 (WPSC)
Switch Capacity	: 1 Amp
Inrush Current Capacity	: 10 Amps for 10 mSec
Duty Cycle	: 100%
Repeat Accuracy	: ± 0.1%
Scale Accuracy	: ± 10 %
Reset/ Test	: Manual Touch Switch
Printed Circuit Board	: UL 94V0
Connection	: DIN 43650 ISO-4400/ 6952
Indicators	: LED's to indicate phases
On Time	: Adjustable from 2-40 Sec
Off Time	: Adjustable from 30 sec to 45 min.



Compressed Air Application

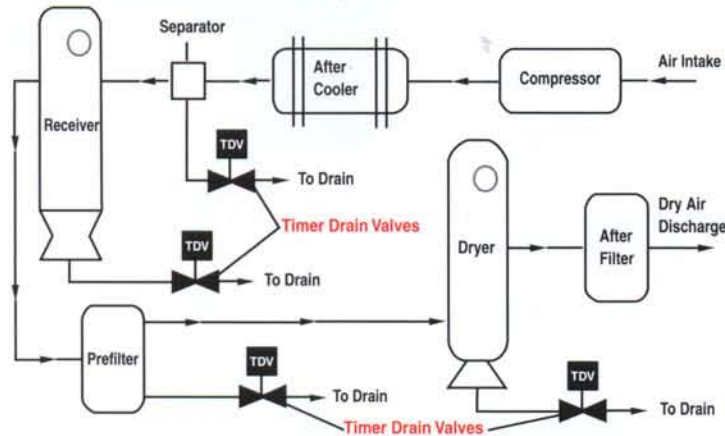

Strainer/ Shutoff Valve

Use strainer/ shutoff valve to filter scales, rust and other debris from condensate.

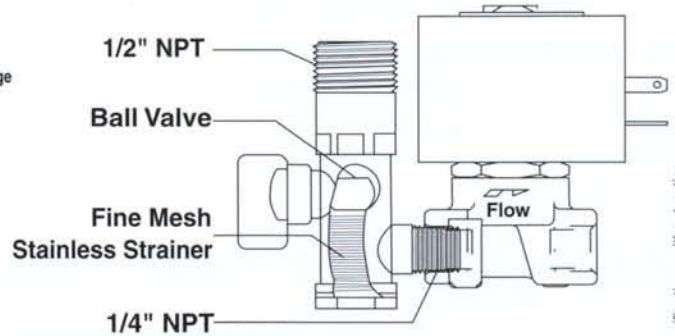

Timer and Accessories

- **Timer Kit** **272-839-001**
- **Strainer/ Shutoff Valve Kit** **272-851**
- **Connector** **272-873**

* For ordering purpose below mentioned nomenclature should be followed, eg., WPSCXB210D4-17308-Voltage.

* The catalogue numbers listed on front page are for reference only.

Note: For 'ATEX' certified products, please consult ASCO.

ASCO

ASCO (INDIA) LIMITED
147, Karapakkam Village,
Chennai - 600 096.
Tel : +91 44 2450 4252/ 61
Fax : +91 44 2450 2270
email: engg@sanmargroup.com
asco5@sanmargroup.com

Branches:
CHENNAI
KOLKATA
MUMBAI
NEW DELHI
PUNE
VADODARA

9, Cathedral Road, Chennai 600 086 India Tel: +91 44 2811 8480 Fax: +91 44 2811 3166
4th Floor, Chowringhee Court, 55 Chowringhee Road, Kolkata 700 071 India Tel: +91 33 2282 2447/ 2448/ 2449 Fax: +91 33 2282 2190
407, Swastik Chambers, Sion-Trombay Road, Chembur, Mumbai 400 071 India Tel: +91 22 2522 9639/ 640/ 643 Fax: +91 22 2522 9646
M-2, Third Floor, South Extension Part II, New Delhi 110 049 India Tel: +91 11 4259 7999 Fax: +91 11 4259 7910
406-408, IV Floor, Century Arcade, Narangi Baug Road, Off Boat Club Road, Pune 411 001 Tel: +91 20 2612 1855 Fax: +91 20 3058 5859
701, Alkapuri Arcade, Tower B, 7th Floor, R C Dutt Road, Vadodara 390 007 India Tel: +91 265 234 4144 Fax: +91 265 233 9748

A constituent of  **SANMAR** Engg Corpn Ltd